

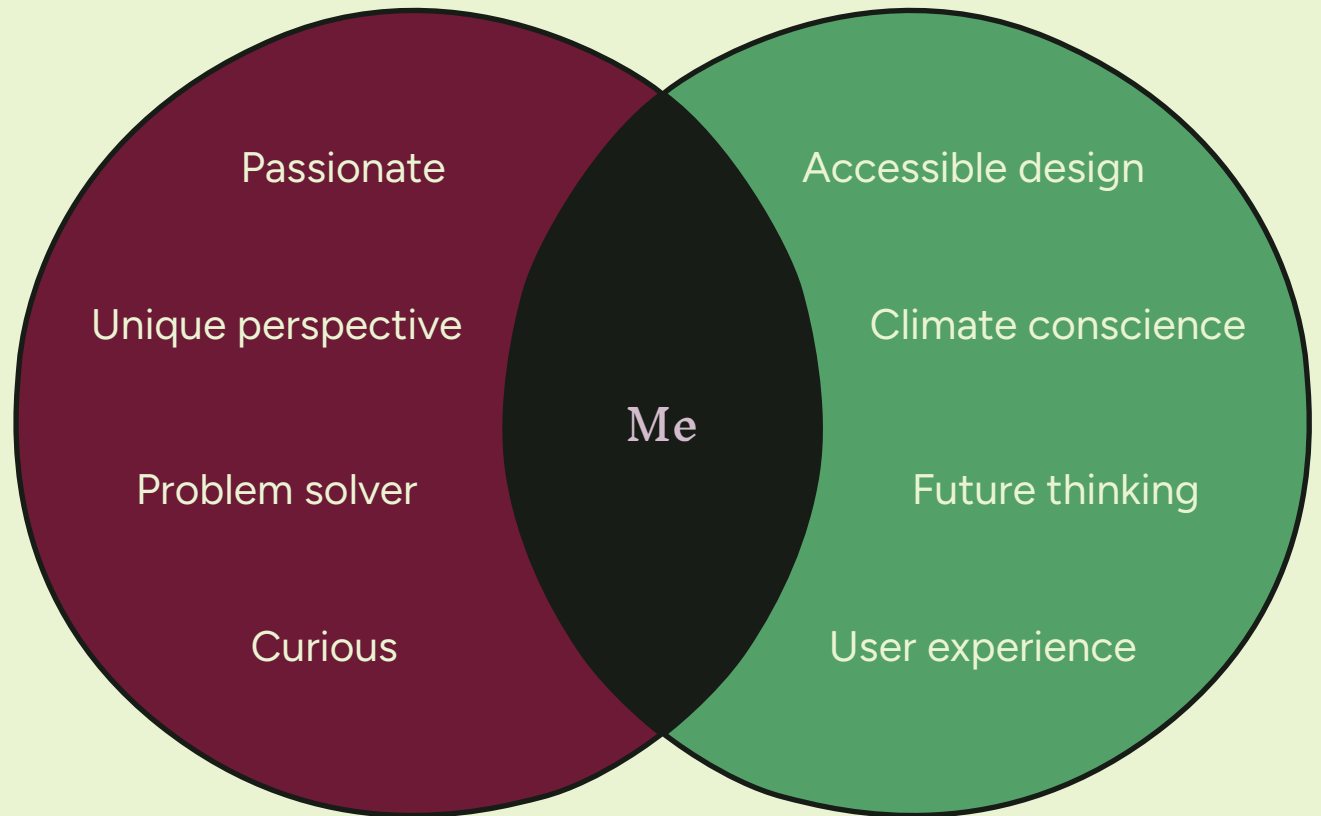

Emily Rose Sharp
Design Portfolio



Hi! I'm Emily, a designer with a passion for tackling climate and social issues.



Education/Experience

- Visual Communicator for Eala Impacts and Plan A Materials Warehouse starting as an internship achieved through Bright Green Business
- Part time Store Associate role at Barnardos charity shop
- First Class Bdes (Hons) Product Design at Edinburgh Napier University (Graduated July 2022)
- Climate Change and Carbon Literacy Upskilling course at University of Glasgow
- B&Q Kitchen, Bathroom, and Bedroom Showroom Advisor/Designer

Skills

- Brand identity
- Community research
- Concept ideation
- User experience
- Model making
- Campaign building
- Collaboration

Contact Me

Email: emilyrose.sharp@outlook.com

Number: 07908 515081

Instagram: [@emilyrosesharp_design](https://www.instagram.com/emilyrosesharp_design)

Website: emilyrosesharp.com



My Projects

01. Don't Recycle

To design a manifesto and campaign to redesign and redefine the eco plastic industry.

02. Plan A

Create an exhibition for the Plan A Materials Warehouse concept on circular economy in Edinburgh and Scotland

03. Leith Local Place Plan

Creating visuals for the proposed Local Place Plan by Eala for Leith.

04. Project Phoenix

Redesigning a derelict fossil fuel space in Hamilton for SGN.

05. Radicals

An app for activists to discover protests and connect with like minded people.

06. EdinBRIC

Creating illustrations to fit in the EdinBRIC brand guide and showcase their values.

07. Personal Bee Helper

To design a product made from recycled wooden pallets for a live client.



OI. Don't Recycle

To design a manifesto and campaign to redesign and redefine the eco plastic industry.

The Problem

Bio plastics, biodegradable plastics, and compostable plastics have been rapidly emerging in recent years as a 'sustainable' replacement to standard plastics.

This is true when they are fully regulated and have a proper way of disposal, but that is where the problem lies. Through research I found that many people believe that eco plastics can be recycled or just left out in any natural environment thinking that they will break down.

This project created a manifesto and campaign to redefine, redesign, and realise the problems to create real change.

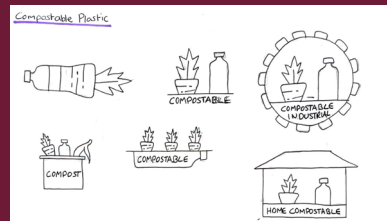
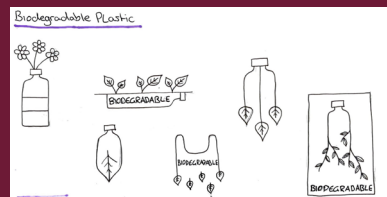

Worms?

People seem to like the idea of having worms in the certification marks

Worms are a very literal link to composting. This will help users link eco plastics to their disposal potential

Worm connotations from other people

- Wriggle
- Earth
- Mud
- Composting
- Pink
- Pink
- Bug
- Compost bins
- Lines

Keep similar reasoning as previous certification marks but add worms

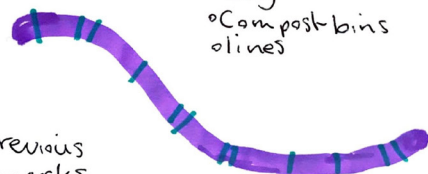

THE ECO PLASTIC COFFEE EXPERIENCE

Brought to you by



Check out the video here!

<https://www.emilyrosesharp.com/don-t-recycle>

CREATIVE CONSCIENCE



SHORTLISTED

This project was shortlisted for a Creative Conscience Award

First Certification marks designs:



Final brand design:



Certification Mark development with new 'worm' design element:



'Don't Recycle' campaign name chosen to directly get the point across and be controversial at first glance.



The final certification mark design that will have one or more applied to an eco plastic next to the 'Don't Recycle' logo.

The branded colour version is the basic but the black outline is available if a company doesn't have a wide variety of ink colours available, or if it is to be embossed.

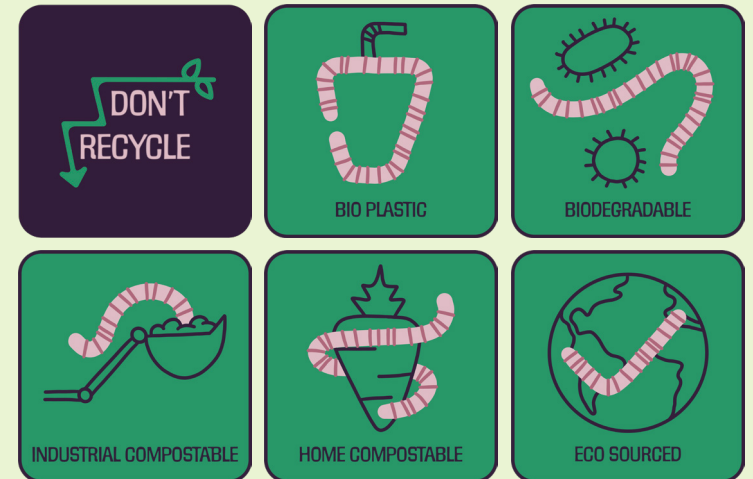

Branding Development

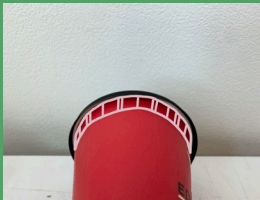
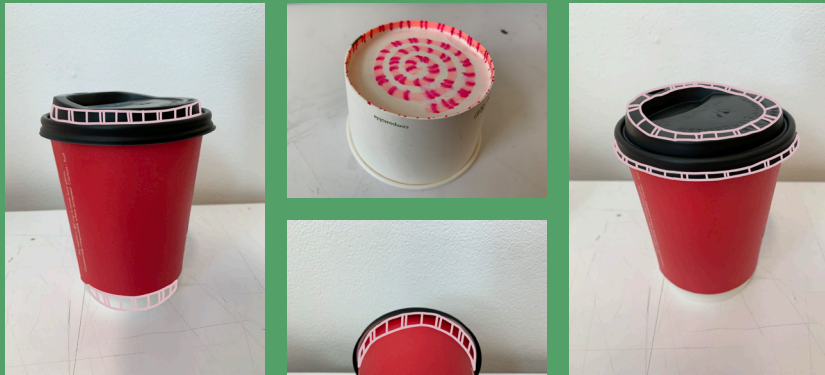

Worm like swirl on the base lets other people see that it is an eco plastic while drinking.



Worm like ridges around the rim allow people to feel that it is an eco plastic through touch.



If the certification marks have worn off or if it has broken down it can still be identified.

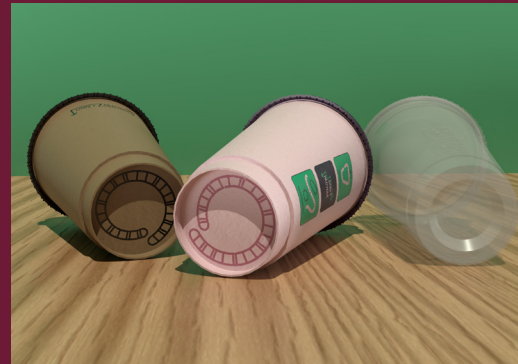

Identifier Markings Development

Follow the Instagram campaign below for public user focused and informative posts!

@dont_recycle_



Or to see posts aimed to people in the eco plastic industry, then check out the LinkedIn page below!

dont-recycle



Social Media Campaign

DON'T RECYCLE

A MANIFESTO AND CAMPAIGN TO REDEFINE, REDESIGN, AND REALISE THE PROBLEMS IN THE ECO PLASTIC INDUSTRY.

THE DISPOSAL (Manifesto Part One)

DON'T RECYCLE, POLYMINATE INSTEAD!

POLYMINATE
Verb
The act of disposing eco plastics correctly so they can be processed and return to a natural bio state.



The best and worst disposal options

THE PRODUCT (Manifesto Part Two)

SINGLE USE PACKAGING CAN BE OKAY!

Focus on food packaging contaminated



Biodegradable
Fully bio based Better Ideal Compostable

THE DESIGN (Manifesto Part Three)

WORM RIDGES
Added touch point for identification

WORM GRAPHICS
Helps identify eco plastics if broken apart

Updated certification marks



Detailed development book and technical pack for this project is available on request.

Plan A
MATERIALS WAREHOUSE

**Edinburgh's circular
economy hub for the
construction sector**

02.
Plan A

Create an exhibition for the Plan A Materials Warehouse concept on circular economy in Edinburgh and Scotland

What is Plan A

Plan A Materials Warehouse is a project I worked on through Bright Green Business internship. They have the goal to create a circular economy hub for the construction sector in Edinburgh.

Created by the same minds behind Eala Impacts, the goal was to have better options and access for reusing materials that would otherwise be demolished and bought new.

My Role

I was hired to be a Visual Communicator. I researched a wide variety of topics and created visuals to convey the information I found and created graphics to displace concepts created by Eala. Some of the key topics were:

- Construction material supply chains now and compared to the past
- Local crafts and trades in Edinburgh
- The history of Guilds in Edinburgh and Scotland
- The lifecycle of buildings and their materials

This work is displayed on their website www.plan-a.scot and have recently been printed and ready to be displayed at a future exhibition.

Style and Inspiration

The style I was asked to explore through the following illustrations and graphics was posters created during the World Wars. This was because they were created with older crafting processes and have a hook to them that we wanted to recreate.

This style is mostly focused on the general branding of Plan A and the first three posters.

I wanted to embrace warm welcoming colours with punchy headings. The script text was chosen as it also hints back to a history of crafts and trades.



THERE IS STILL TIME TO MAKE
CONSTRUCTION CIRCULAR



Get your recirculated
parts and materials at:

Plan A
MATERIALS WAREHOUSE

Plan A
MATERIALS WAREHOUSE



PLANET

PROSPERITY

PEOPLE

Plan A
MATERIALS WAREHOUSE



By using deconstruction over
raw materials, there will be
no 'waste' to manage.

Using the concepts of RIBA workstages, the triple bottom line, and deconstruction to create advertising posters for Plan A. The aim of these were to be initially eye-catching and thought-provoking to intrigue people into learning more about Plan A and a circular economy in construction.

Construction

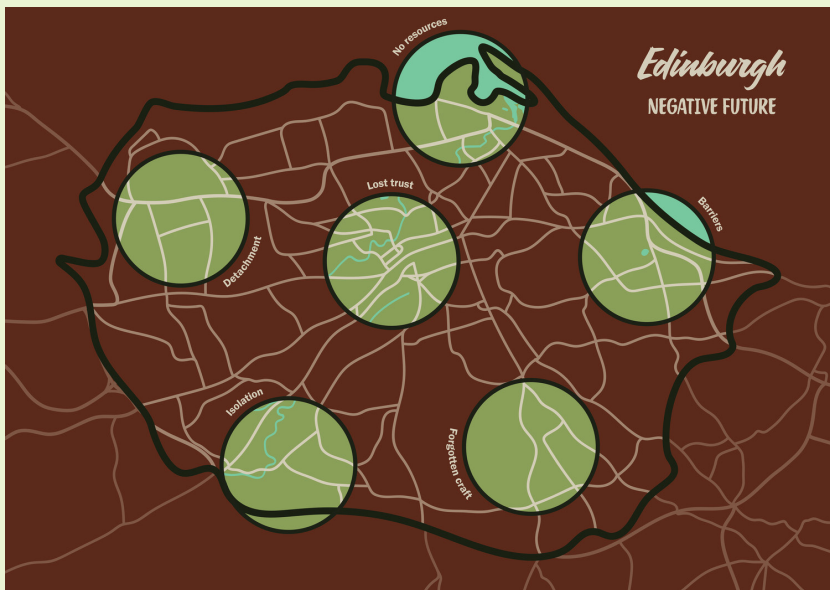

These four diagrams show a past present and future timeline of Edinburgh and its connection to materials and production.

The past was full of local crafts and trades which we have highly lost and replaced with outsourcing products and throwing used materials 'away.

The future can go one of two ways. Either creating smaller tunnel vision and detachment by continuing on the path we're on, or opening more by teaching the past trades and crafts and adding modern circular concepts.

Edinburgh Timeline

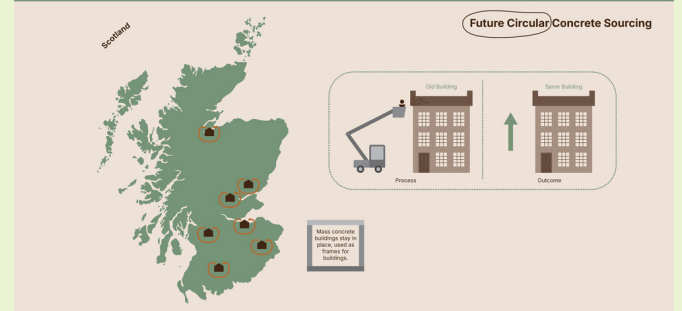
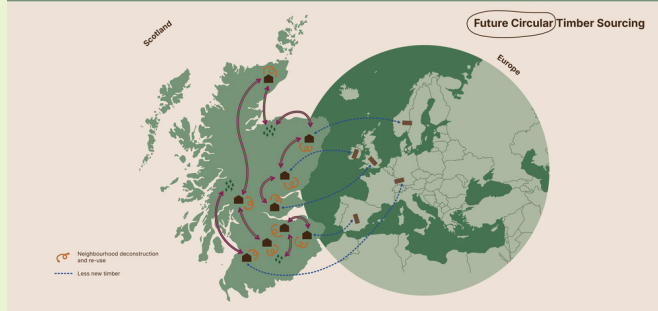
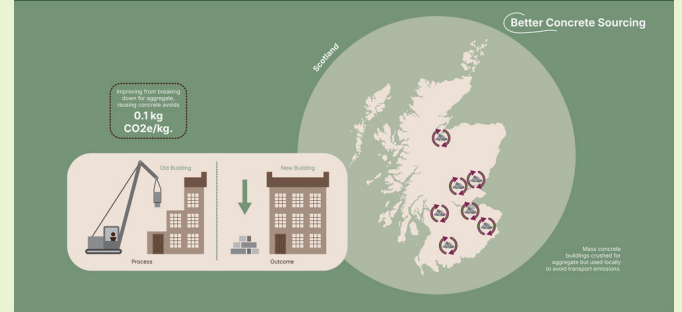
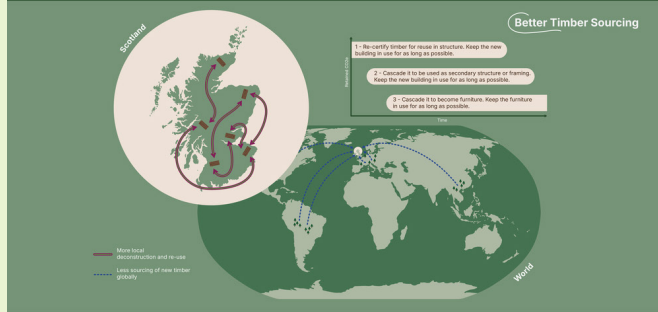
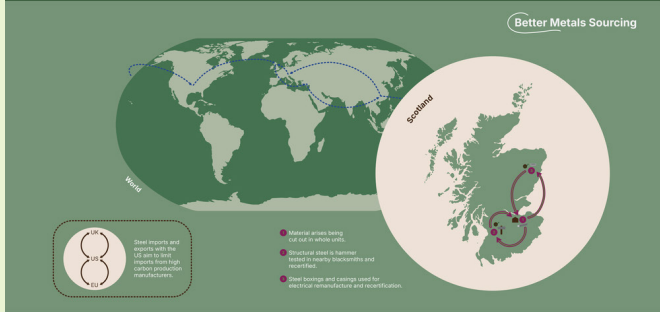
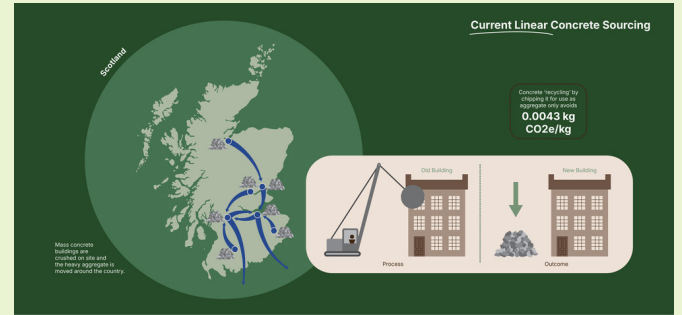
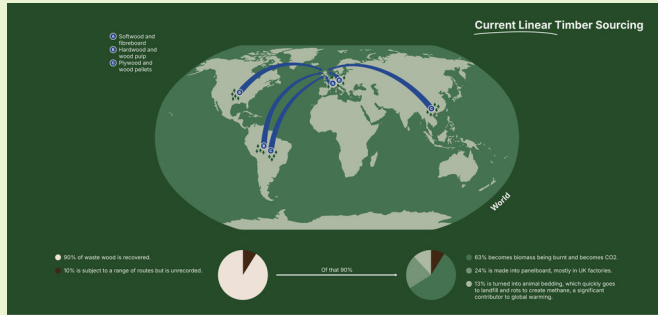
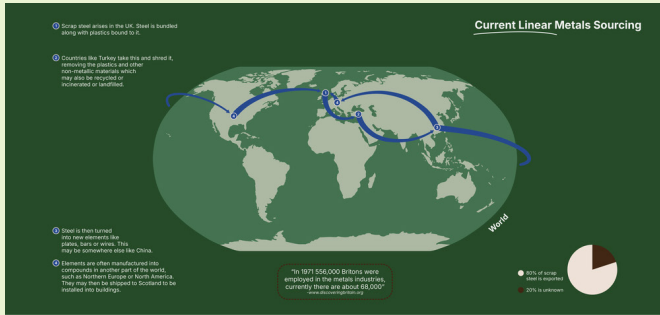

This series show a material mapping of metal, timber, and concrete. The top area shows the current linear processes in place, the middle shows proposed better sourcing, and the bottom shows an ideal future circular process of sourcing and using the materials on a smaller local scale.

Material Mapping

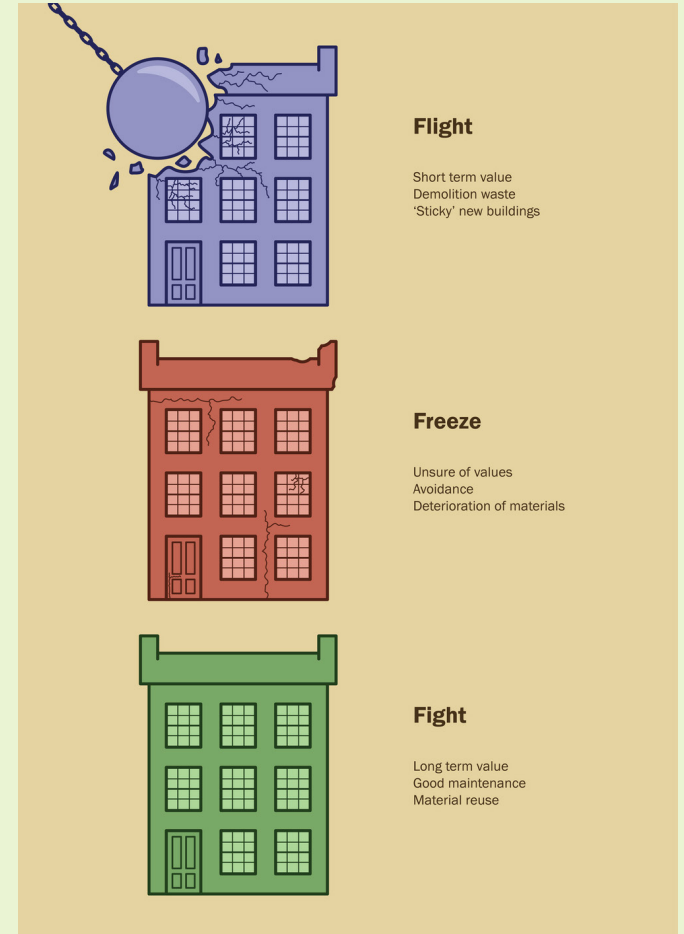
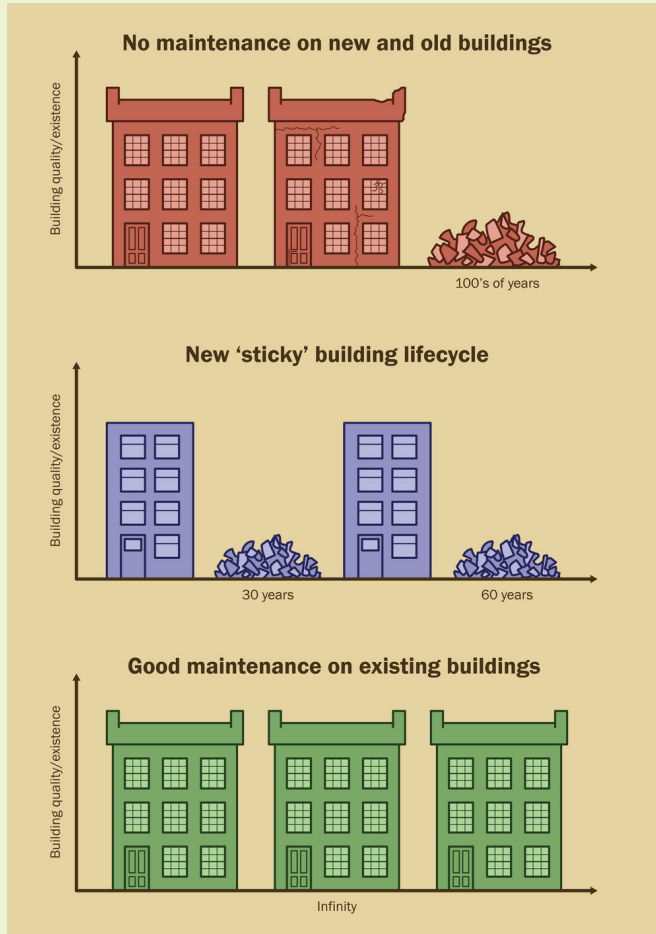
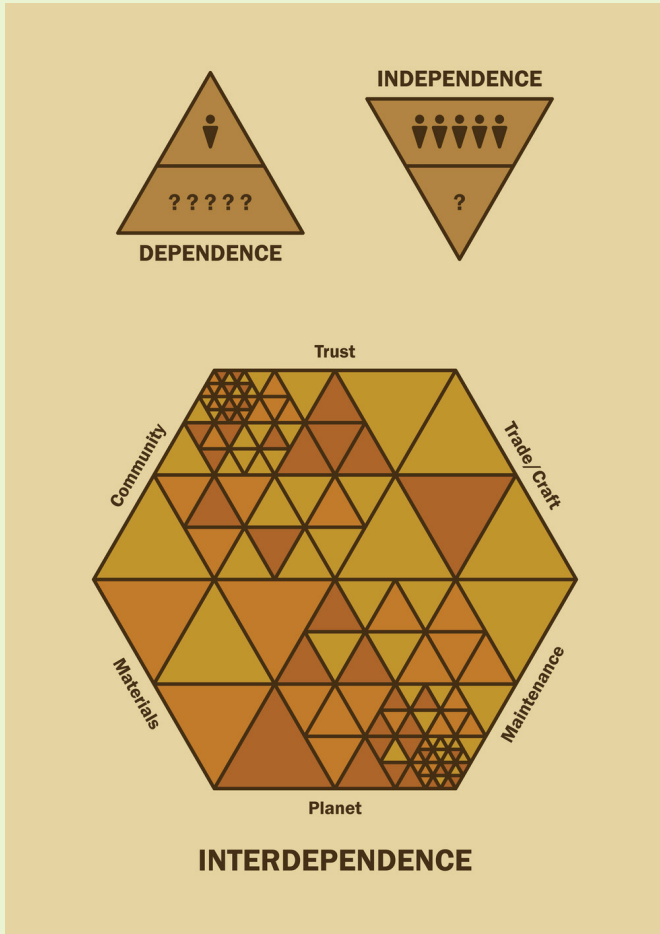

The psychology of people is touched on in these graphics. Exploring how close and dependent people were in the past and comparing that to the independence of today. Then using tenements as a diagram tool to show different possible outcomes of how people treat their buildings, as well as how the building was created at the beginning (old tenements vs new builds)

Community

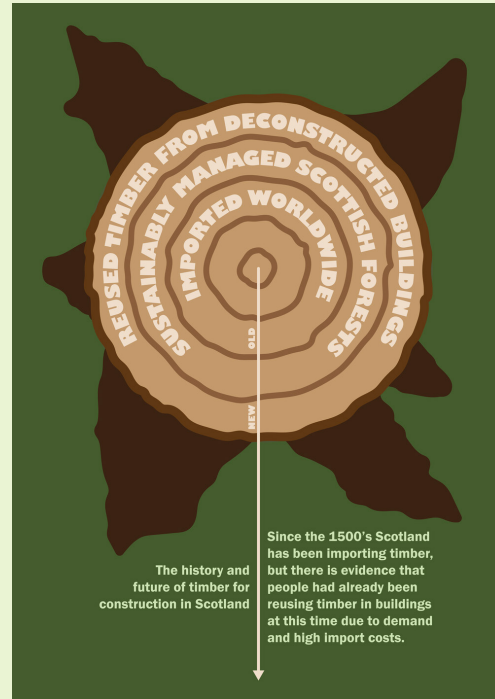
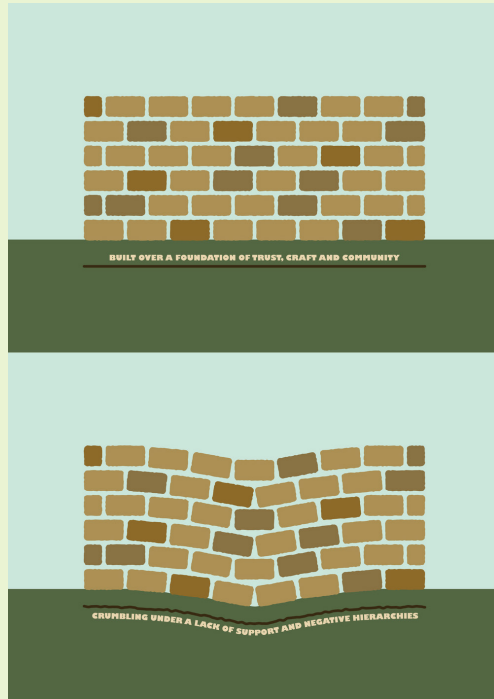

Materials



03.

Leith Local Place Plan

Creating visuals for the proposed Local Place
Plan by Eala for Leith.

What Is It?

The Local Place Plan for Leith is currently getting produced by Eala Impacts on behalf of the three Community Councils (Leith Harbour and Newhaven Community Council, Leith Central Community Council, and Leith Links Community Council) in Leith. This will then be submitted to the City of Edinburgh Council to go towards the creation of the City Plan 2040.

My Role

My part of creating the Leith Local Place plan was to create all advertising and marketing material. This included leaflets and posters that were handed out and pinned inside local establishments and building a page on Ealas website where people can check for updates. I also created many variations of a map of Leith to display current situations and proposed new ideas.

I also got the opportunity to partake in events to get the word out of the surveys and let people know how to get their voice heard. I put together the surveys on Jotform and helped analyse the responses which I then condensed into infographics.

Progress

This project is still in the process of being finalised, so to see its progress so far you can check out its page on the Eala website here: <https://www.ealaimpacts.co.uk/leith-place-plan>



04. Project Phoenix

Redesigning a derelict fossil fuel space in
Hamilton for SGN.

Models made by me.

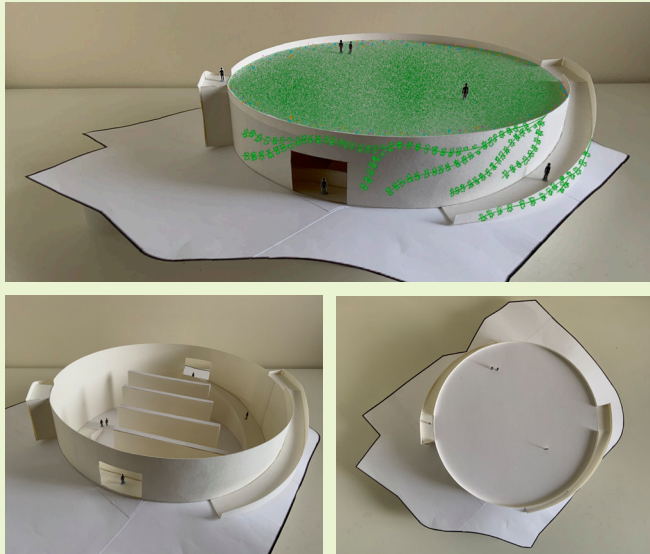

Phase 1

This design takes the existing gas holder and redesigns it, as the people of Hamilton state it as an eyesore but also apart of their history.

The concept shows the theme of beauty and decay by embracing the exterior and adding climbing ivy to the sides. The inside is a local art gallery with a wildflower rooftop garden.

The art gallery could be rented out for special exhibition events and/or there can be competitions held to have peoples artwork on show for a set length of time.

Models made by me.

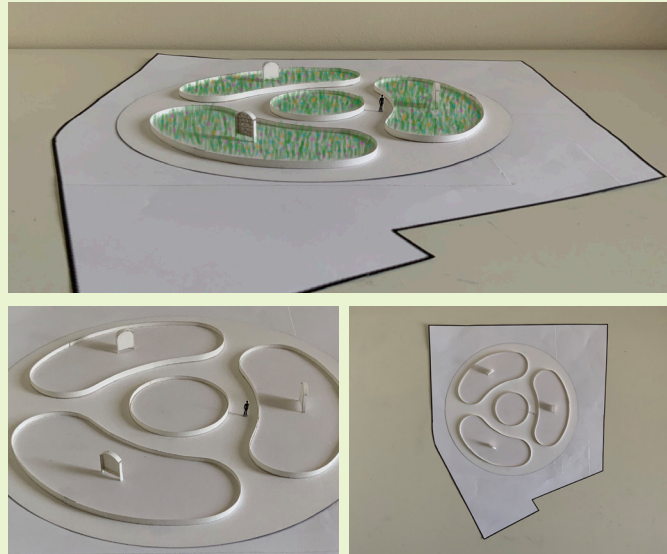

Phase 2

For this area we decided to improve biodiversity in the open concrete area with large wildflower beds and insect/bee hotels placed inside them. The design takes on the shape of the sustainability symbol.

This concept can also easily be implemented into other sites to help local biodiversity. We plan for it to not be fully open to the public to protect the bee/insect hotels and create a safe space for the biodiversity to thrive. We contacted a local Primary School that would be interested in naming the insect/bee hotels.

Models made by other team member.



Phase 3

We have decided to build a refill station to help the Hamilton community shop more sustainably while also allowing them to earn an income by being employed at the shop.

Inside we want to sell a range of items from tea, dried foods, cleaning products, and hand sanitiser. The shop itself would include all the produce, stations for weighing and paying and areas for which would include a break room, stock room and a staff toilet. To improve biodiversity we included a green roof which will also aid in the insulation of the shop.

Project Design Phases

Sketches by me and renders by other team member

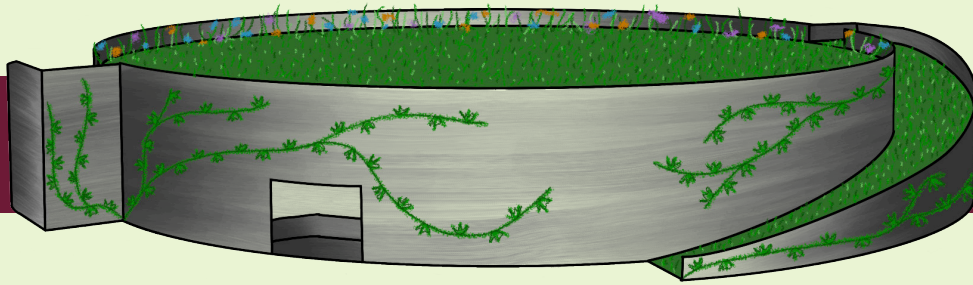

Gas Holder Landmark

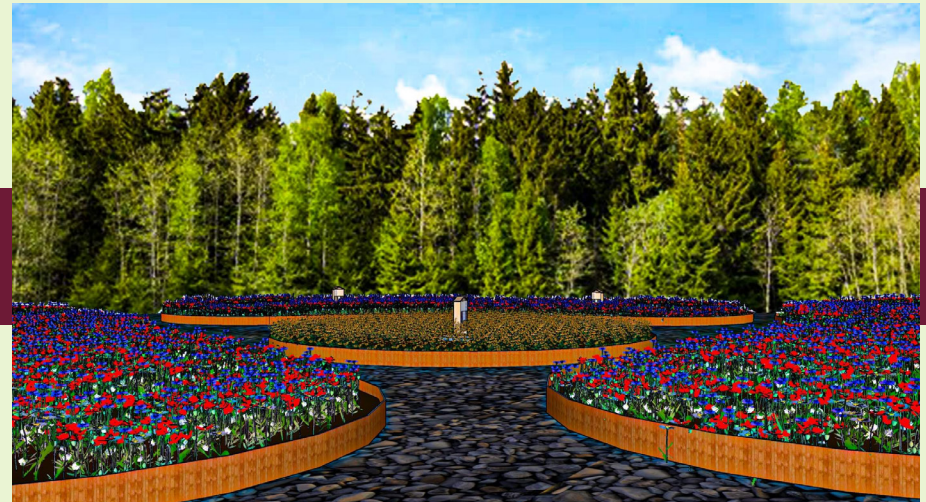

Wildlife Farm

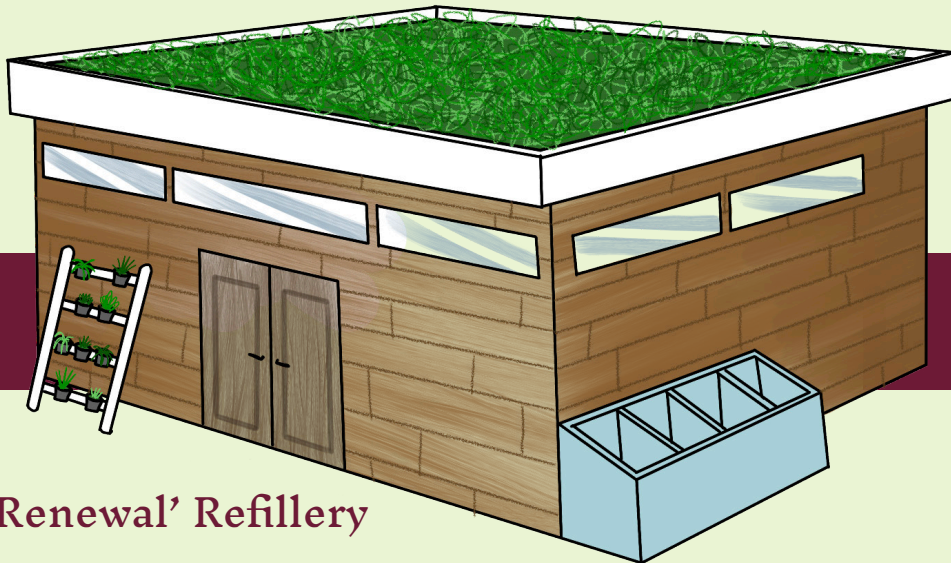

'Renewal' Refillery



Detailed development book and technical pack for this project is available on request.



05. Radicals

An app for activists to discover protests and connect with like minded people.

The Idea

The concept is inspired by dating apps but warped to finding other activists and protests in the users area. It can be difficult to get into the world of activism if people don't have existing connections so the app allows people to find whatever they're looking for most in activism.

Target Market

Anyone that is wanting to get into a new area of activism. Anyone who doesn't know people who are part of their movement. Anyone who has moved to a new area and wants to get into the activism scene there. Anyone who wants to keep updated on the local protests.

User Needs

The app needs to have options to change between looking for people and looking for protests. It should have all the most relevant information quickly available as well as ways to find out more information and chat further. It needs to have all relevant safety requirements.



Ideation

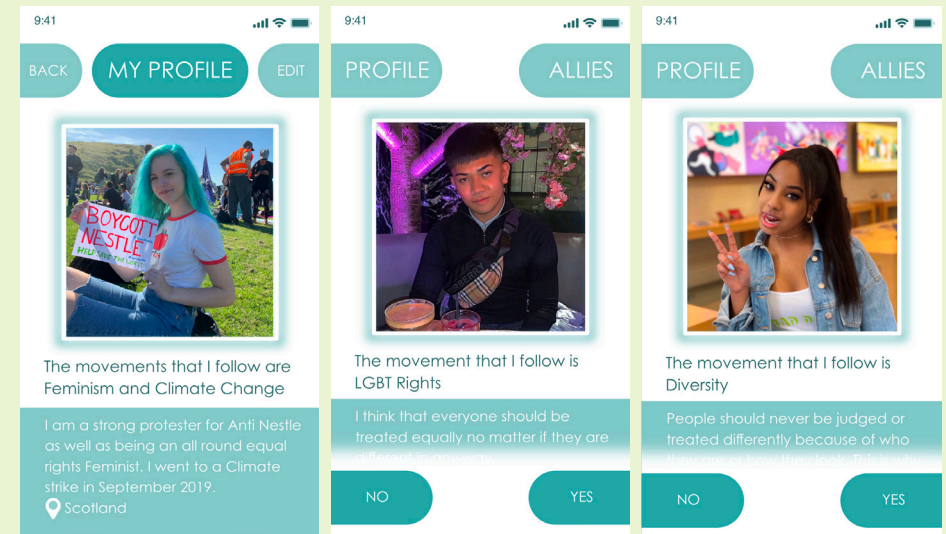

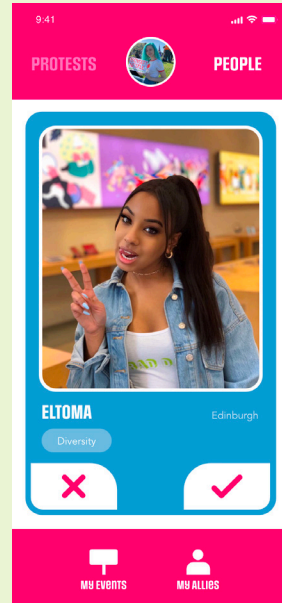
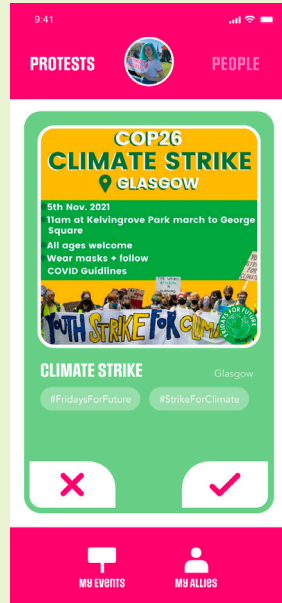
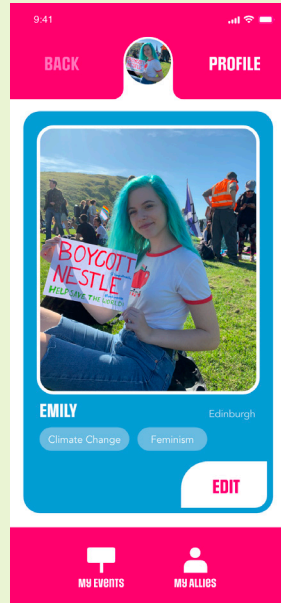
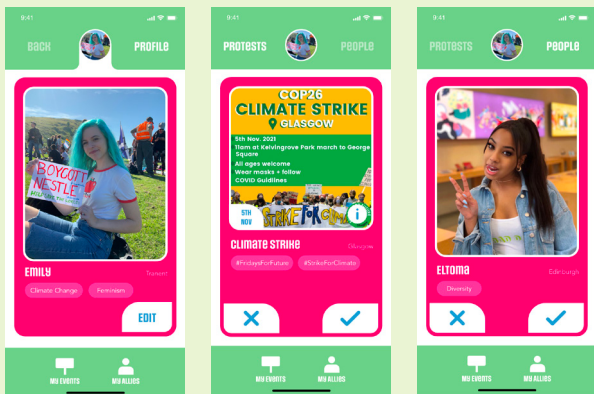
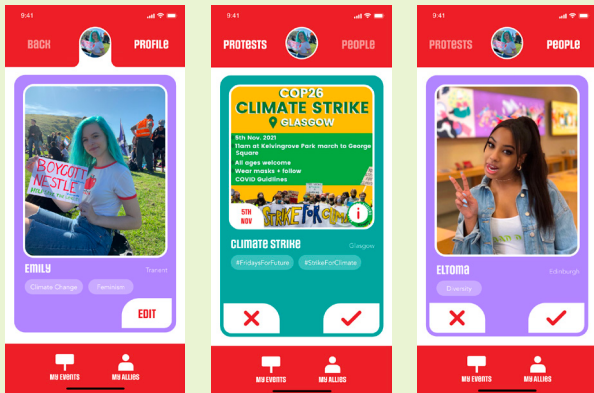
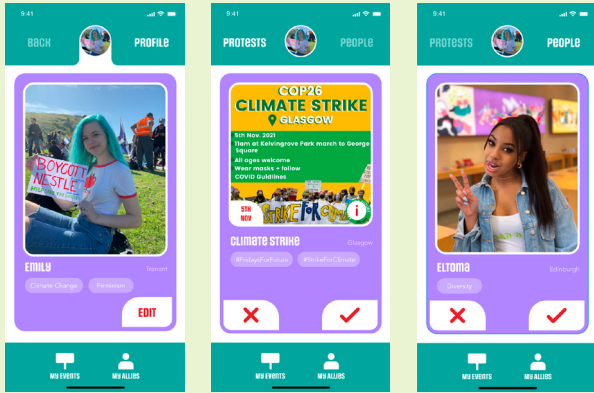

The name 'Radicals' came from people using the word to describe activists as being extreme to try and give them a bad reputation. So this app flips the word and reclaims it.

The colour pallet wanted to be loud and proud just like the users. The experience of the app aims to excite the user and get them invigorated to go out and make a change.

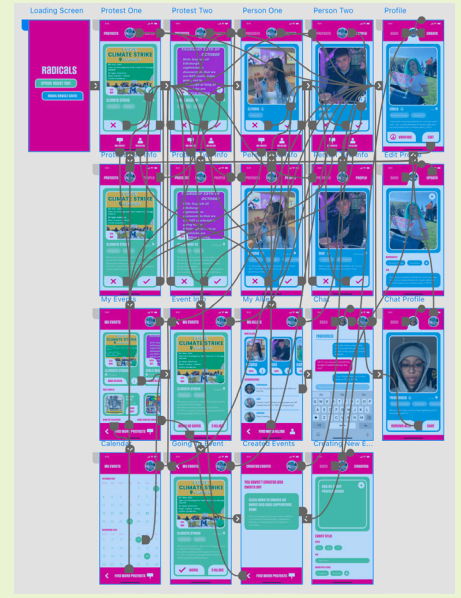
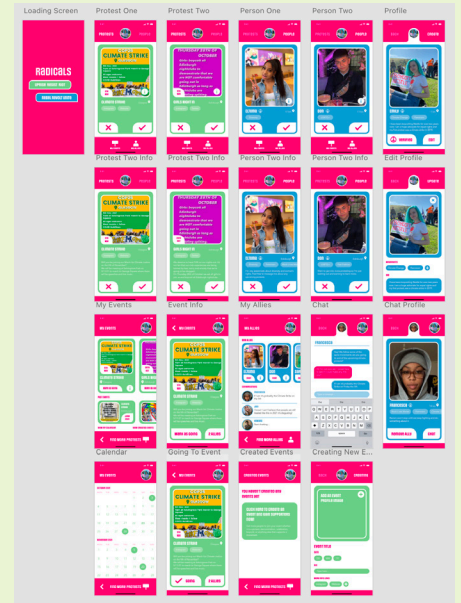

The App Flow

Development and Branding



06. EdinBRIC

Creating illustrations to fit in the EdinBRIC brand guide and showcase their values.

What is EdinBRIC

EdinBRIC (Edinburgh Building Retrofit and Improvement Collective) is an organisation to help people get involved with their communities to collectively take care of their buildings. More information can be found on their website at www.edinbric.scot

My Role

My work for EdinBRIC was completed while working with Eala as they are part of the team there.

My job was first to take the brand and website, that had been created by Eido Studio before I joined, and create illustrations and icons to go on the website. These were to help convey the core purpose and values of EdinBRIC.

More recently I have been creating a range of promotional graphics for the company to use at events. Including business cards, flyers, posters, a flag and updating their informational graphics boards on their retrofit rover.

Existing Branding

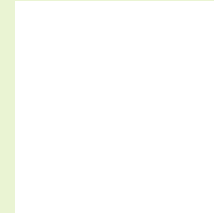

#FFFFFF

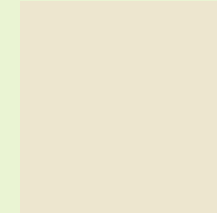

#EDE6CF



#9AB178



#453E32



This logo had already been created for the brand so all further graphics had to align with this simple and rounded style.

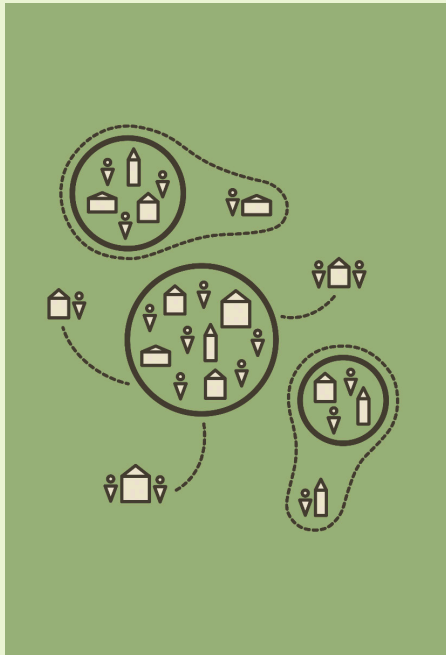

Start a community group, or join forces with an existing one

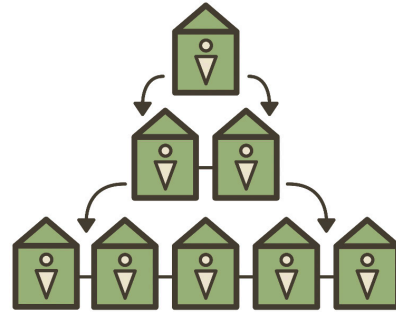

Find an existing group

Our dream is to see the city covered with groups supporting one another to carry out building retrofit and improvement projects. Click below for existing groups in Edinburgh.

[View groups](#)

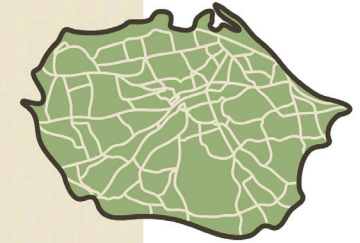

Create a group

There are many [different ways to start groups](#). This may be an [neighbourhood voluntary association](#), a [constituted owners' association](#), or if you are a tenant then [Living Rent](#) organises local branches. Our Case Studies give examples of Edinburgh citizens setting up groups and working together. If you have an idea for a group and want support, please contact us.



[Contact EdinBRIC](#)

[Read case studies](#)

Have an event

If you already have a group or would like to inspire neighbours into action then we can help you. We can bring a Retrofit Roadshow or the Retrofit Rover to your community. Contact us to find out more.

[Contact us](#)

[See events](#)

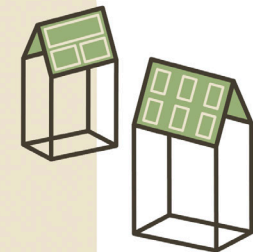

EdinBRIC



Founded in 2023, EdinBRIC is a vibrant collective of community groups, professionals and support organisations. We are better working together! Discover more about our collective vision by clicking below.

[About us](#)

[See case studies](#)

EdinBRIC helps turn your individual ambition into a win for people and planet



EdinBRIC

Website Icons and Illustrations

EdinBRIC Case Studies



Dudleys Home Improvement Group
Certificate of low-carbon solar panels - by typology



Porty Community Energy
Solar panels on community buildings



Brighton and Rosefield Energy Efficient Homes Association (BREEHA)
Collective building condition surveys



Bruntsfield Area Net Zero Action Initiative (BANZAI)
Collective building condition surveys



Kirk Street
Owners association and district heat feasibility

Are you next?



EdinBRIC Scotland
01463 222222

Resilient Communities

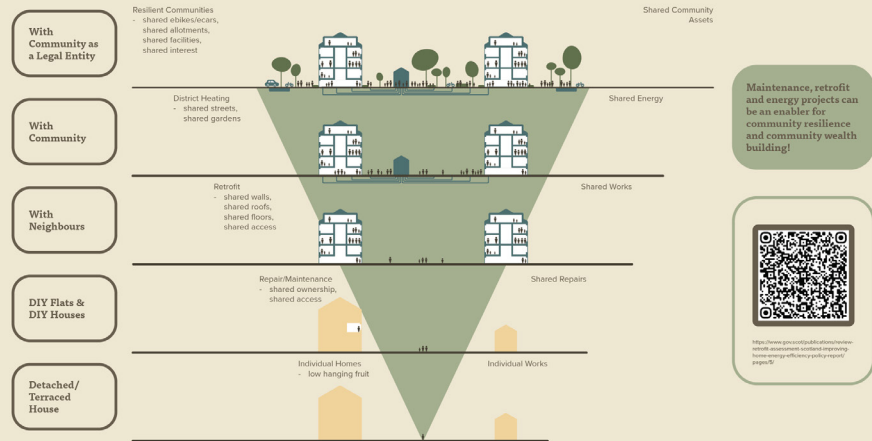

Tenements A, B, C (& D)

<p>A - Owners Association</p> <p>Follow Scottish Law Commission recommendations and:</p> <ol style="list-style-type: none"> 1. Set up an Owners Association and appoint a manager 2. Hold at least one annual meeting 3. Approve a repair budget 4. Ensure building information is provided to property registers 	<p>Scottish Law Commission Recommendations</p> <p>How to set up an Owners Association?</p>
<p>B - 5-Yearly Building Inspection Report</p> <p>A 5-yearly inspection report starts with a survey of your building. The report sets out any maintenance and energy efficiency improvement needs over the next 5 years.</p>	<p>Novoville 'Shared Repairs' and 'Shared Works'</p> <p>Eala 'Building Passport'</p>
<p>C - Cash in Bank Account for 'Maintenance' and 'Reserve'</p> <p>Set up bank accounts to save for any future planned maintenance, and for future improvements. The 5-yearly inspection report gives a budget for every year which is used to decide how much goes into the bank accounts.</p>	<p>Save some money for:</p> <ul style="list-style-type: none"> • Daily 'Maintenance' • Future 'Reserves' • Repair 'Backlog'
<p>D - 'Deficit'/Backlog</p> <p>Most tenements have backlog repairs. Plan these backlog repairs alongside maintenance and improvements.</p>	<p>Banking for Owners Associations:</p> <ul style="list-style-type: none"> • Community accounts • Business accounts • Lendology

Who are you?

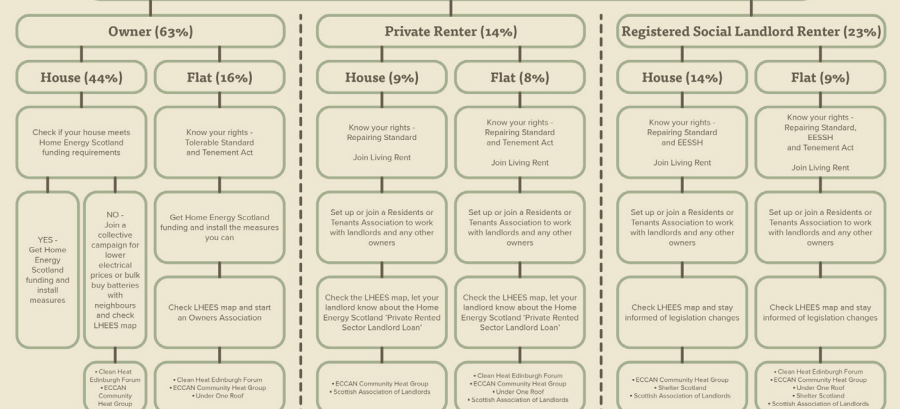

Retrofit Rover Redesign

DIY Energy Efficiency

Renters

- Thick curtains, and close them at night
- Secondary glazing, friction fitted
- Removable draught proofing to letter boxes, under doors, around windows, chimneys etc.
- LED light bulbs
- Small heating controls, boilers and radiators
- You could even administer the Owners Association for your landlord

Owners

- Secondary glazing
- Maintain rainwater goods
- Heat pumps for detached property
- Start an Owners Association
- Get heat network ready for fitted property - check LHEES
- Loft insulation

How Does Heat Escape?

Remember to check your tenancy agreement!

Urban Local Heat and Energy Efficiency Strategy (LHEES)

Heat networks to provide decarbonised heat for tenement buildings

City of Edinburgh

Heat Network Zones low to high demand

Scan here for CEC heat networks and building assessment reports.

<https://www.edinburgh.gov.uk/heat-networks-build-up-assessment-reports>

Mutual/Common

Legislation

A typical tenement maintenance plan:

- Yearly – clean gutters and check roof covering and flashings
- Every 5 years – paint and repair windows, gutters and downpipes
- Every 5 years – professional property inspection
- Every 10 years – paint close and stave walls
- Every 10-20 years – replace bitumen felt roofs and flashings
- Every 25-30 years – replace tiled roofs
- Every 50-100 years – replace slate roofs

Make up a case study here.

<https://www.edinburgh.gov.uk/tenement-maintenance-plan>

A Common Future

SOLAR PANELS FUND ROOF MAINTENANCE &

WASTE HEAT FUNDS DRY WALLS AND DRAUGHT FREE WINDOWS

SPONSOR A GARDEN

USE WASTE HEAT FROM TRAINS TO HEAT HOMES

HELP WATER SYSTEMS BY GREENING LANDS

HEAT EXCHANGER

Make up a case study here.

<https://www.edinburgh.gov.uk/tenement-maintenance-plan>

Retrofit Rover Redesign



07. Personal Bee Helper

To design a product made from recycled wooden pallets for a live client.

The Client

'Better Pathways' is a charity based in Birmingham who aim to help people with their mental health. One of the main activities they offer is a wood craft workshop for people to go in and make a product out of wood to be sold.

We were to create new and exciting designs that could possibly be put into production with the theme of 'Empowerment Through Production'.

For my design to achieve empowerment in the maker I wanted the product to have a purpose that is beneficial for the environment. This also fits well with the recycled wooden pallet material.



These are some examples of existing products that Better Pathways have built and sell.



Handmade at our Woodcraft Centre

I wanted the design to fit in with the rustic handmade aesthetic. On top of this their workshop only have so many tools available.

Ideation

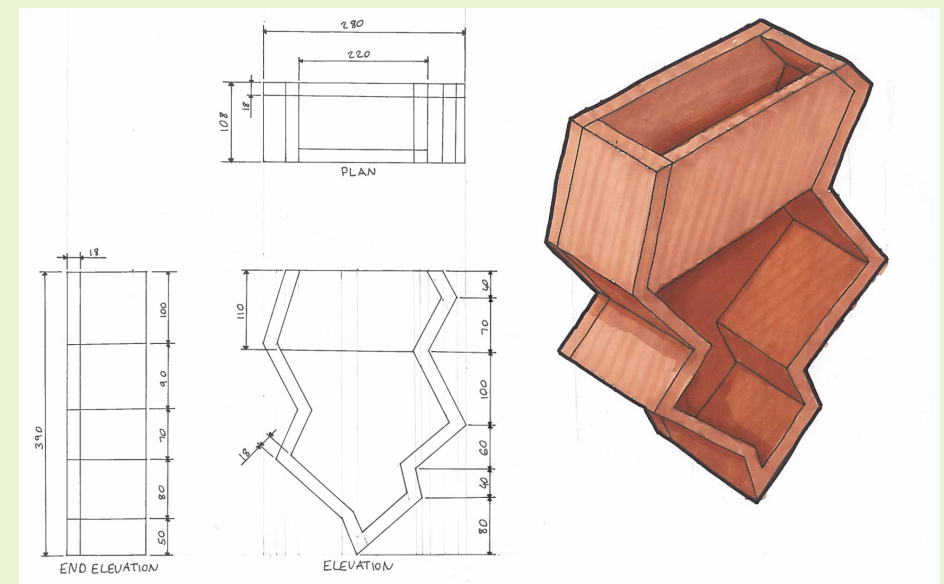
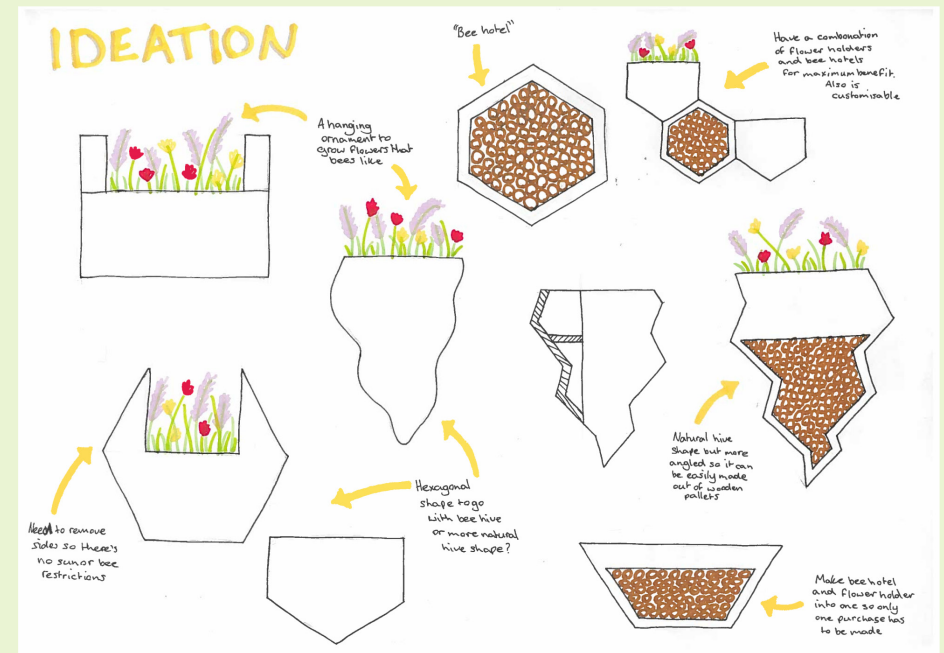

Bee hotel requirements:

- At least 100mm depth
- An over hang on top to protect from rain and wind
- Bamboo canes, bramble sticks or other hollow wooden sticks with the hole approximately 6-10mm in diameter.

Plants that attract bees:

- Lavender
- Bee Balm
- Pansies
- Mint
- Snowdrops
- Milkweed

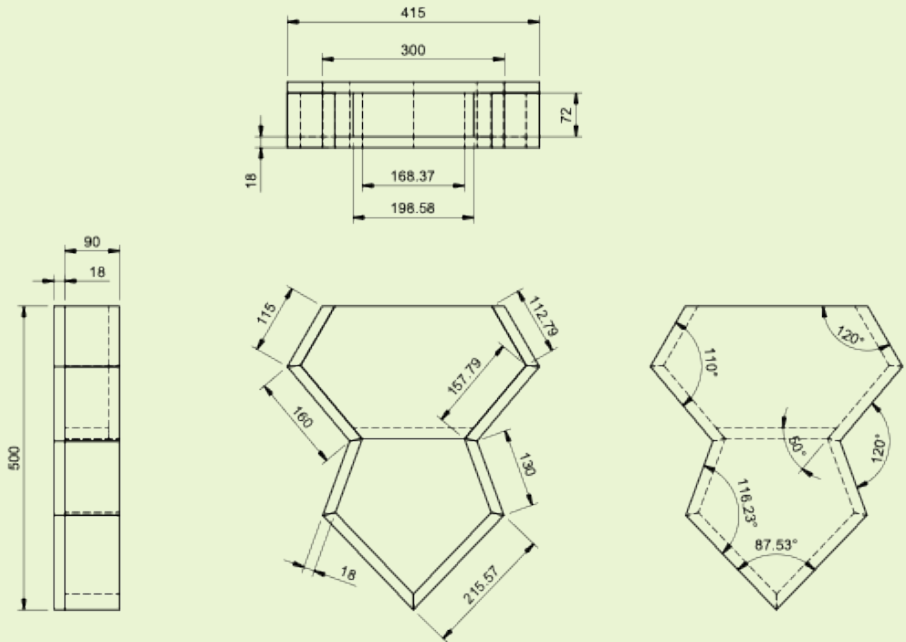
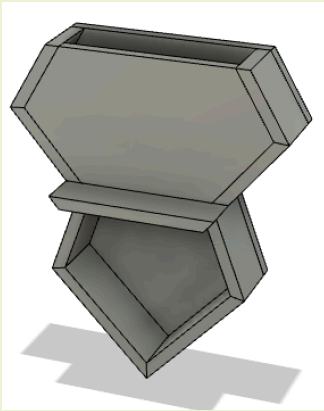

Dept	Technical reference	Created by Emily Sharp	01/10/2019	Approved by	
		Document type		Document status	
		Title	Urban Bee Helper	DWG No.	
		Rev.	Date of issue	Sheet	1/1

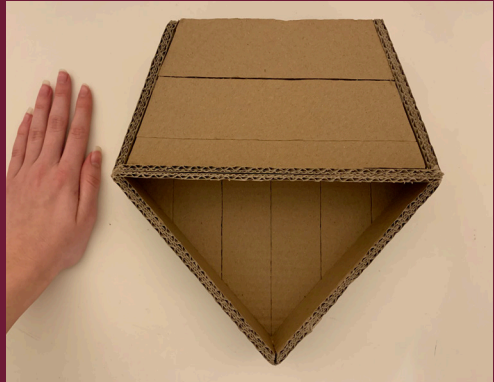
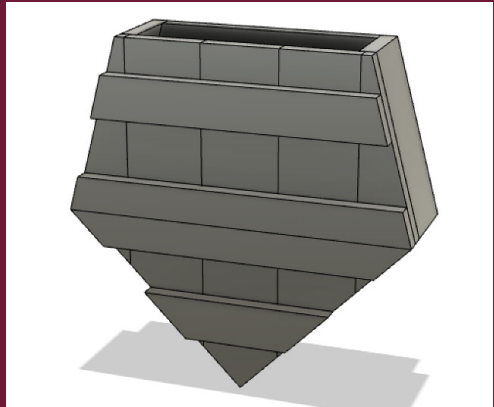
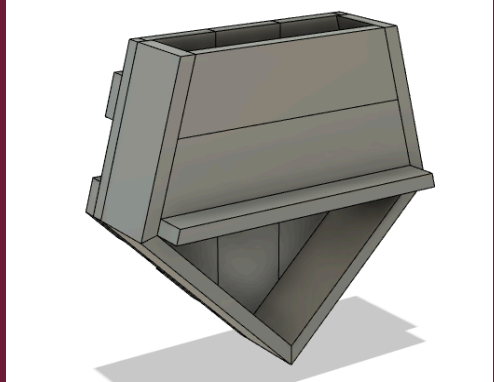

Most of the development stemmed from trial and error of making the bee hotel, whether this was on CAD with cardboard or wood.

The design had to be simplified as it was challenging to keep track of all the angles. I wanted it to be simple enough for the people at Better Pathways to produce with limited resources.

A key change in design was moving the planter from the top to the sides. This is so there could be drainage holes and to avoid the be hotel from getting water damage.

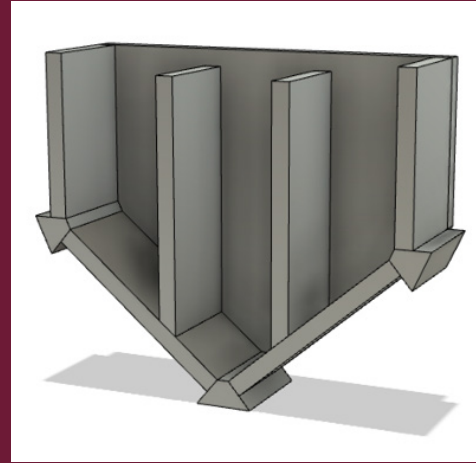

My design was chosen to produce and sell. The above image is their recreation.

Final Outcomes

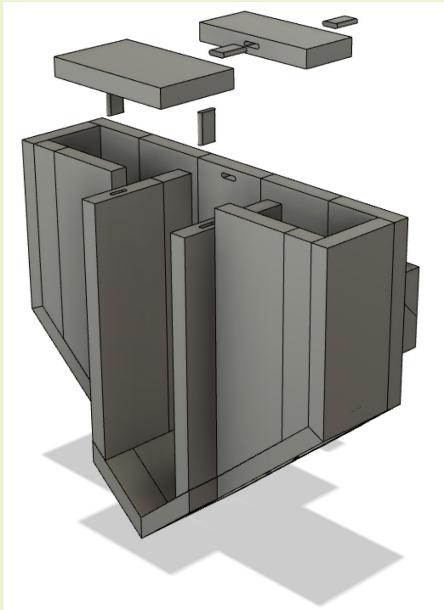
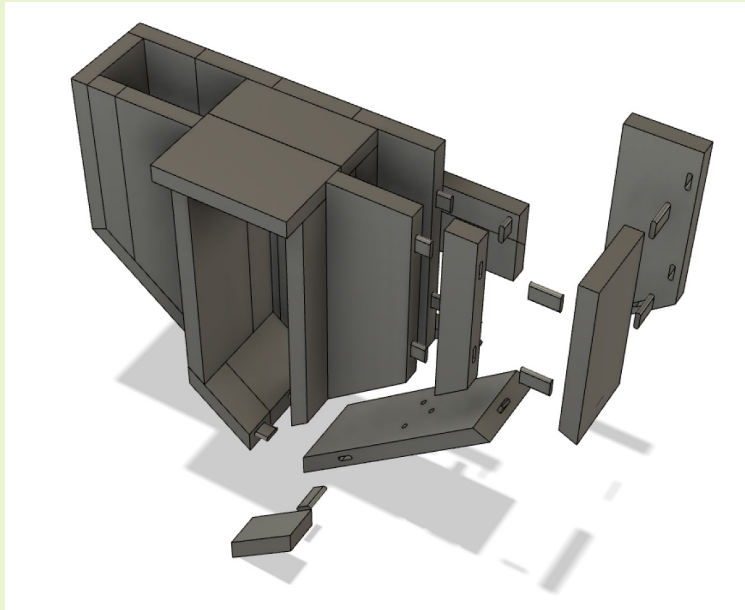

PERSONAL BEE HELPER





Email: emilyrose.sharp@outlook.com

Number: 07908 515081

Instagram: [@emilyrosesharp_design](https://www.instagram.com/emilyrosesharp_design)

Website: emilyrosesharp.com